

HOGAR IZQ EcoDesign

PANADERO

PRODUCT PLUS

ECODESIGN



**EXTERNAL AIR
INTAKE**



3 MM STEEL BODY



HEATING VOLUME



VERMICULITE LINING



PRINTED GLASS



WOOD LOGS 50 CM



CLEAN GLASS SYSTEM



DOUBLE COMBUSTION

MEASURES

DIMENSIONS H x W x D	530x600x500 mm
GROSS/NET WEIGHT	94/81 kg
FIREWOOD ENTRANCE	460x280 mm
SMOKE FLUE	Ø 150-153 mm Top

CHARACTERISTICS

CAST IRON GRILL	
NOMINAL HEAT OUTPUT	5,9 KW
EFFICIENCY	77 %
CO EMISSIONS	0,10 %
HEAT RESISTANT PAINT	800°C
CERAMIC GLASS HEAT RESISTANCE	750°C

EAN 8426964190823
REF. PROVEEDOR 19082

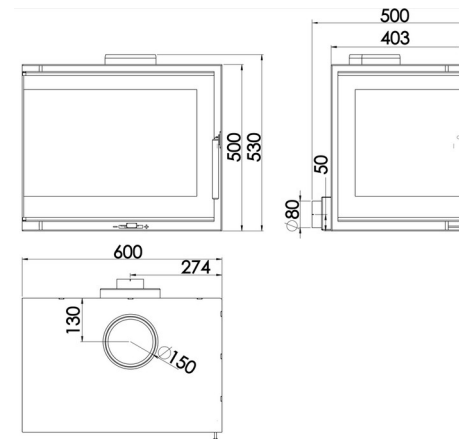

HOGAR DER/IZQ EN